

RECOMMENDED MOUNTING INSTRUCTIONS FOR ALL MMBLEDLPR4 SERIES LIGHT BARS

*****Proper installation of this product is the sole responsibility of the installer*****

Size of mini-bar: 17.25" wide x 9.5" deep x 2.75" tall

Follow Instructions Included with Mini-bar for Proper Install

1. Locate a flat surface on vehicle and position light parallel to the ground.
2. In the interior of the vehicle, loosen upholstery at mounting location. For non-roof mounts adapt bolt pattern to surface provided.
3. Use center-punch if available to start five (5) holes. The four (4) mounting holes should be positioned following the mini-bar layout described below. A fifth hole should be punched and drilled for the wire feed. Drill the four (4) mounting holes with a 1/4" drill. Drill the wire exit hole with a 3/8" drill.
4. Decide where on the vehicle you will install the Pattern Changing Button (PCB)
5. Run the wire from the button to the wire exit hole and push through to the outside the vehicle
6. Crimp the two PCB wires into the butt connectors outside the base of the light
Connect either wire to either butt connector
6. Insert Red/Black Duplex through 3/8" hole
5. Connect **red wire** to power (+) and **black wire** to ground (-)
6. TEST LIGHT and the Pattern Changing Button
7. Position bolts over mounting holes
7. Install washers and hex nuts and tighten down mounting bolts until gasket seals light to the surface of the vehicle.
8. Replace upholstery to original position if applicable.

PROBLEMS INSTALLING YOUR LIGHT OR LIGHT NOT WORKING?
DO NOT RETURN LIGHT TO PLACE OF PURCHASE!!!! PLEASE REFER TO BACK OF THIS SHEET FOR REPAIR/WARRANTY INSTRUCTIONS

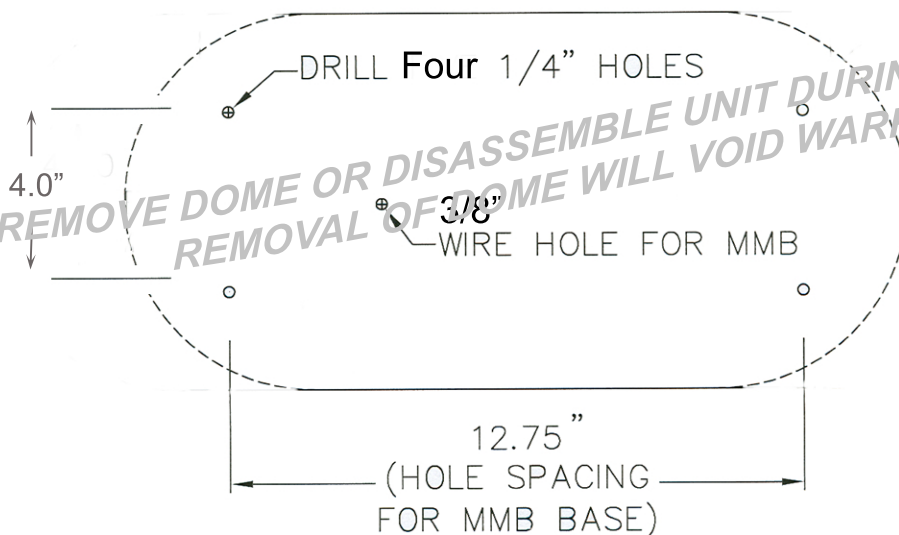

*******CLEAN DOME WITH WATER ONLY*******

DRAWING NOT TO SCALE